

## ELECTRIC MECHLIFT PRO™

### Versatile moment absorbing lifting unit

Electric Mechlift Pro™ is a versatile moment absorbing lifting unit that is easily adapted to many types of handling solutions.

Mechlift Pro™ can be fitted with standardized or customized gripper tools, and with accessories such as rotation units, brake units, programmable stop positions, and much more.



Versatility makes Mechlift Pro™ a professional universal lifter with a wide range of applications.

Typical objects handled with electric Mechlift Pro™ are panels, carpet rolls, tanks, doors, windows, cable reels, vehicle doors, sun roofs, car seats, windscreens and car bonnets.

# Versatile moment-absorbing lifter

## Flexible lifting unit

Electric Mechlift Pro is an ergonomically designed moment-absorbing lifter which can be used for many lifting solutions. It can be fitted with standardised or customized grippers, and with accessories such as rotation units, brake units, programmable stop positions, and more.

## Several configurations

Electric Mechlift Pro is modular and can be supplied in many different configurations. It can also be integrated with Powerdrive drive units for driven sideway motions, or with Mechbelt linear unit for an automated "pick and place" type of handling.

## Moment-absorbing

Electric Mechlift Pro consists of telescoping aluminium profiles that are anodized and thereby completely maintenance free. In the pillar unit there are torque-absorbing sliding blocks, (in 400/650 kg torque-absorbing wheels), which enable load outside the lifter's vertical lift shaft.

## Encoder

Electric Mechlift Pro may optionally be equipped with an encoder that reads the axle in the spindle limit switch. This makes it possible to set a lower stop position, as well as a further two stop/start positions along the stroke. The positions are stored in a built in memory in the frequency converter and are not erased in case of power cuts.

## Many application areas

Typical application areas for electric Mechlift Pro are handling of cable rolls, mat rolls, tanks, doors, windows, and various types of automotive parts such as vehicle doors, sunroofs, seats, windshields, hoods, etc.

”

Electric Mechlift Pro is an ergonomically designed moment-absorbing lifter which can be used for many lifting solutions.

”



movomech

movomech

## Technical specification electric Mechlift Pro

Technical data	Mechlift Pro E	Technical data	Mechlift Pro E
Max load <sup>1</sup>	75/150/250/400/650 kg	Motor output <sup>2</sup>	0,25/0,75/1,5 kW
Max torque <sup>1</sup>	500/800/1500 Nm	Voltage	1x230V, N, PE, (±15) 50/60 Hz
Stroke SL <sup>1</sup>	500-2000 mm	Fuse	AT 10
Noise level	<70 dB (A)	Enclosure class	IP 54
Suspension height PH	50-490 mm	Work temperature	5-40°C (indoor use)

<sup>1</sup> Depends on pillar unit

<sup>2</sup> Depends on engine unit

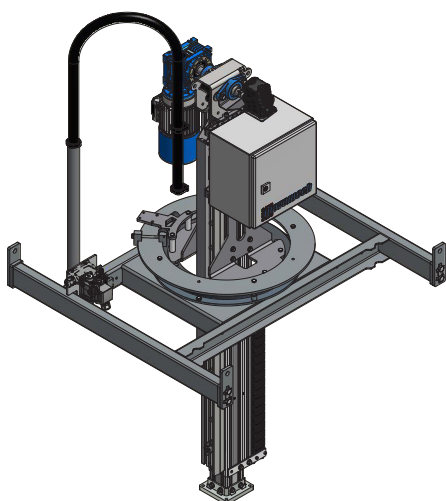

75 kg

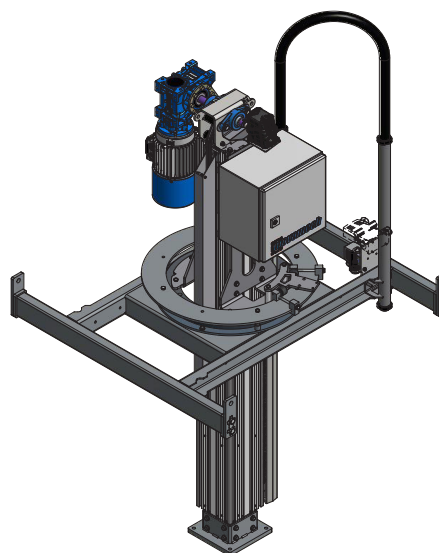

150 / 250 kg

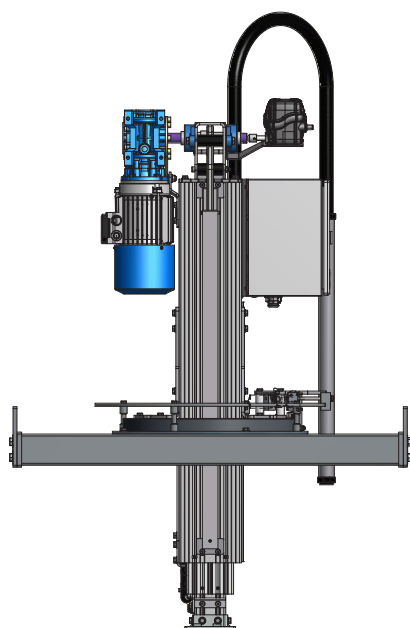

150-3 / 250-3 kg

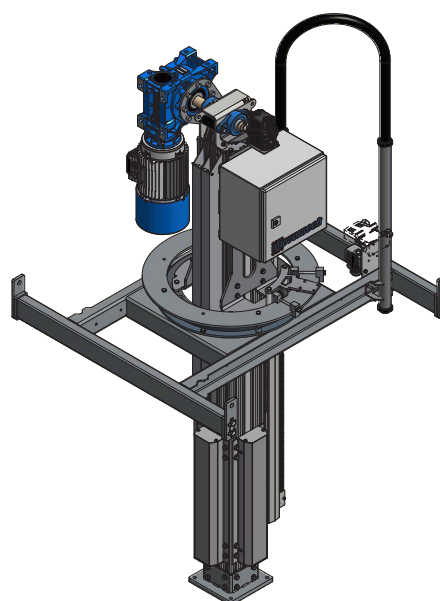

400 / 650 kg

# Overview

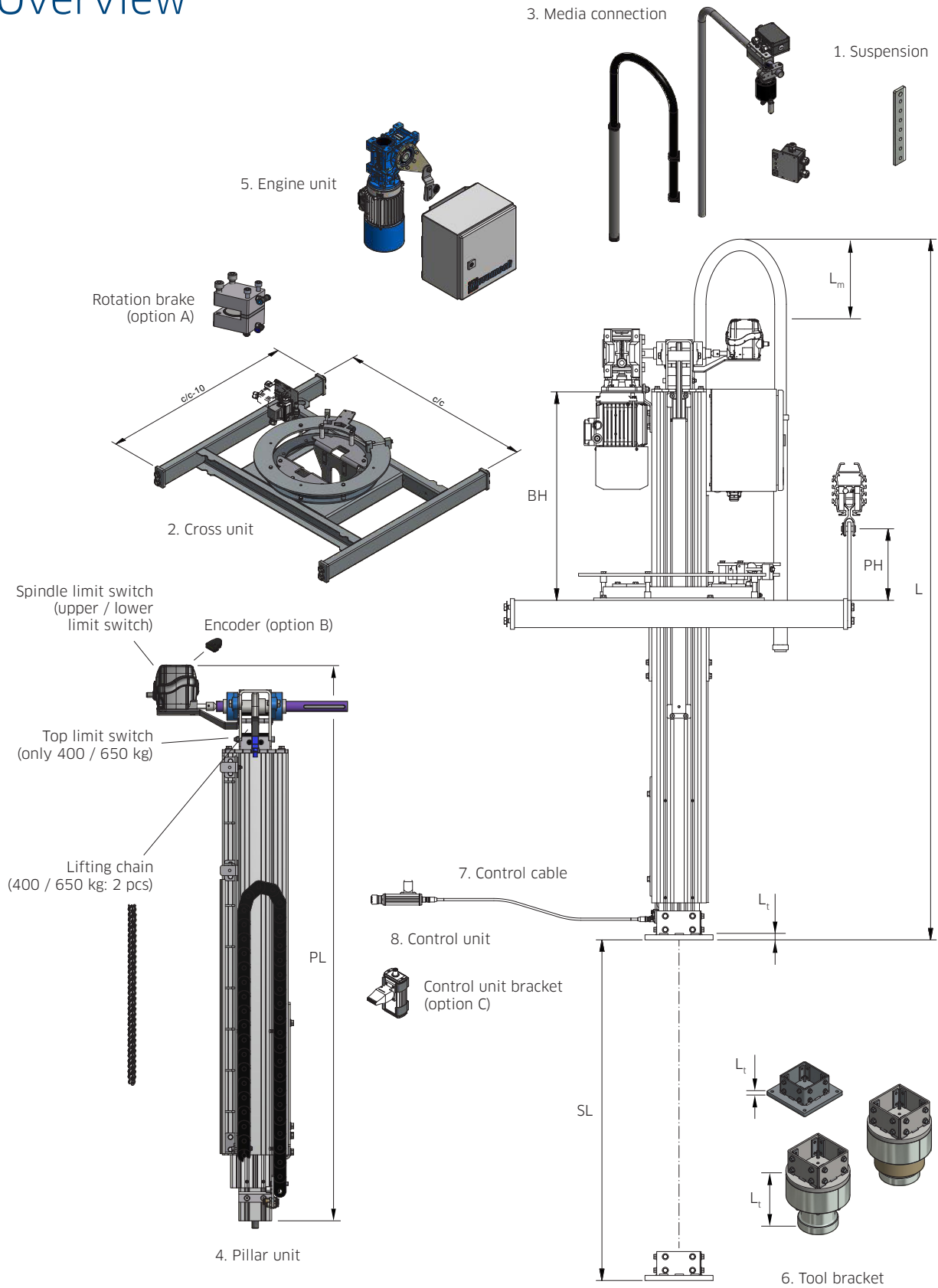

$$L = PL + L_m + L_t$$

**1 + 2 + (3) + 4 + 5 + 6 + 7 + 8 + PH + BH + (A/B/C) : Mechlif Pro E specification**

# 75

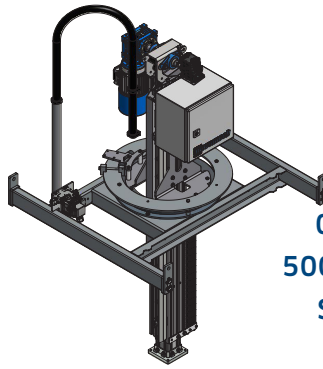

**(5) 75 kg** (Min<sup>1</sup>) Max load  
**120/80** Profile MP  
**500 Nm** Max moment  
**0,25 kW** Motor output  
**0-12 m/min** Lifting speed  
**500-1500 mm** Stroke SL  
**SL+755 mm** Pillar length PL<sup>2</sup>  
**97-168 kg** Tare weight<sup>3</sup>

1. Suspensions	Height PH (mm)	Quantity	kg	c/c	#	#	#
Suspension PH 50	50	4	0,6	-	733833	733835	733837
Suspension PH 90-210*	90-130-170-210	4	1,1	-	742402	740940	740941
Suspension 4x PH 250-370*	250-290-330-370	1	<10	800	742403	740942	740944
Suspension 4x PH 250-370*	250-290-330-370	1	<11	1000	742405	740943	740945
Suspension 4x PH 410-490*	410-450-490	1	<12	800	742404	740946	740948
Suspension 4x PH 410-490*	410-450-490	1	<13	1000	742406	740947	740949
				Ø (mm)	12,5	16,5	20,5
				Fits trolley	LHB	AHB1.1/2	AHB3

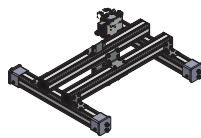

742745 / 742746

2. Cross units	kg	#
Profile cross unit c/c 800	26	742745
Profile cross unit c/c 1000	29	742746

\* Cut to selected suspension height PH, see also Suspensions page 14.

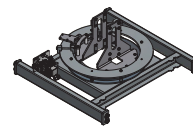

742701 / 742703

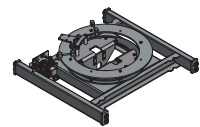

742700 / 742702

2. Cross units	kg	°	#
Steel cross unit, up c/c 800	53	0-310*	742701
Steel cross unit, up c/c 1000	58	0-310*	742703
Steel cross unit, down c/c 800	53	0-310*	742700
Steel cross unit, down c/c 1000	58	0-310*	742702

\* 310-360°, depends on media connection.



A. Option	kg	#
Rotation brake	0,4	742708

3. Media connections	L <sub>m</sub>	kg	#
0-310° (standard)	240	1,4	742736
360° free rotation, 6+12 pol	175	7,3	742737
360° free rotation, 6 pol	175	6,5	742738
360° free rot., 6+12 pol, 2 pneu <sup>5</sup>	175	7,6	742965
360° free rot., 6 pol, 2 pneu <sup>5</sup>	175	6,7	742964

<sup>1</sup> To overcome the frictional force of the sliding blocks

<sup>2</sup> Total length: L = PL + L<sub>m</sub> + L<sub>t</sub>

<sup>3</sup> Depends on configuration

<sup>4</sup> Possible build height BH, see page 15.

<sup>5</sup> Ø4 + Ø8.

4. Pillar units <sup>4</sup>	PL	kg	#
Pillar unit SL=500	1255	29	742710
Pillar unit SL=750	1505	33	742711
Pillar unit SL=1000	1755	37	742712
Pillar unit SL=1250	2005	40	742713
Pillar unit SL=1500	2255	44	742714
Pillar unit SL=500-1500	SL+755	<44	742715

5. Engine units	kg	#
Engine unit 75 kg	34	742740

B. Option	#
Encoder	742256

- The encoder simplifies positioning in the Z direction.
- Mounted in the rotary limit switch.
- Teach-in function.
- Is connected directly to Mechlift Pro (no external PLC).



6. Tool adapters	L <sub>t</sub>	kg	#
Tool adapter MP80	15	2,5	731500

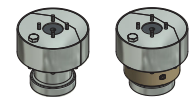

6. Tool adapters	L <sub>t</sub>	kg	°	#
Rotation unit MP80	176	6,9	0-320	739850
Rotation unit MP80 brake	176	10	0-320	739851

7. Control cables*	#
Control cable L=0,6 m	740937
Control cable L=1,0 m	741586
Control cable L=2,0 m	741678
Control cable L=5,0 m	741679
Control cable L=7,5 m	741680

\* Length L from inner profile to control unit.

8. Control units	#
With emergency stop	742192
With emergency stop + protection	742194
With separate em. stop	742240
With separate em. stop + protection	742241

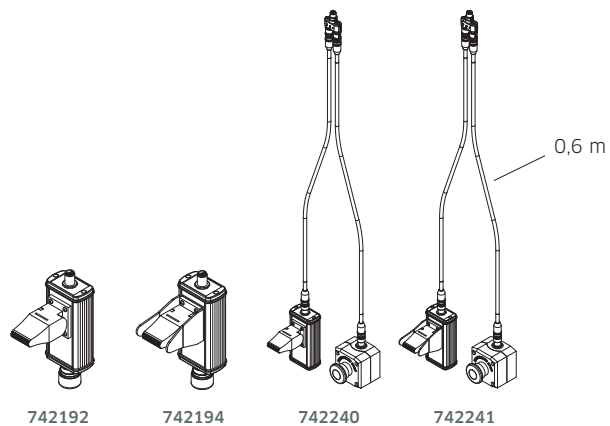

742192

742194

742240

742241

C. Option	Unit	#
Mounting clamp	pc	742242
Wall bracket	set	742243
Adjustable wall bracket	set	742244

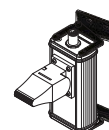
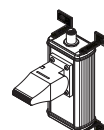
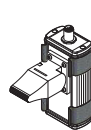

742242

742243

742244

# 150 250

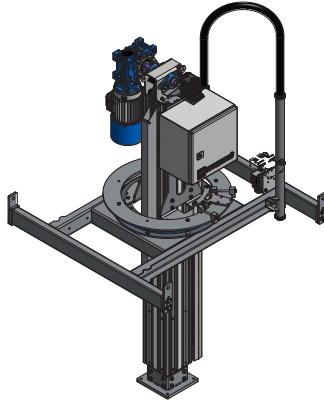

- (5) 150/250 kg** (Min<sup>1</sup>) Max load
- 160/120** Profile MP
- 800 Nm** Max moment
- 0,75 kW** Motor output
- 0-10 m/min** Lifting speed
- 500-1500 mm** Stroke SL
- SL+805 mm** Pillar length PL<sup>2</sup>
- 122-212 kg** Tare weight<sup>3</sup>

1. Suspensions	Height PH (mm)	Quantity	kg	c/c	#	#
Suspension PH 50	50	4	0,6	-	733835	733837
Suspension PH 90-210*	90-130-170-210	4	1,1	-	740940	740941
Suspension 4x PH 250-370*	250-290-330-370	1	<10	800	740942	740944
Suspension 4x PH 250-370*	250-290-330-370	1	<11	1000	740943	740945
Suspension 4x PH 410-490*	410-450-490	1	<12	800	740946	740948
Suspension 4x PH 410-490*	410-450-490	1	<13	1000	740947	740949
				Ø (mm)	16,5	20,5
				Fits trolley	AHB1.1/2	AHB3

\* Cut to selected suspension height PH, see also Suspensions page 14.

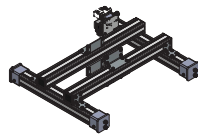

742747 / 742748

2. Cross units	kg	#
Profile cross unit c/c 800	27	742747
Profile cross unit c/c 1000	30	742748

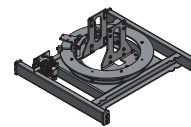

742705 / 742707

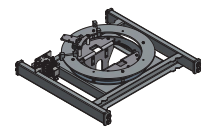

742704 / 742706

2. Cross units	kg	°	#
Steel cross unit, up c/c 800	61	0-310*	742705
Steel cross unit, up c/c 1000	66	0-310*	742707
Steel cross unit, down c/c 800	61	0-310*	742704
Steel cross unit, down c/c 1000	66	0-310*	742706

\* 310-360°, depends on media connection.



A. Option	kg	#
Rotation brake	0,4	742708

3. Media connections	L <sub>m</sub>	kg	#
0-310° (standard)	240	1,4	742736
360° free rotation, 6+12 pol	175	7,3	742737
360° free rotation, 6 pol	175	6,5	742738
360° free rot., 6+12 pol, 2 pneu <sup>5</sup>	175	7,6	742965
360° free rot., 6 pol, 2 pneu <sup>5</sup>	175	6,7	742964

<sup>1</sup> To overcome the frictional force of the sliding blocks

<sup>2</sup> Total length: L = PL + L<sub>m</sub> + L<sub>t</sub>

<sup>3</sup> Depends on configuration

<sup>4</sup> Possible build height BH, see page 15.

<sup>5</sup> Ø4 + Ø8.



4. Pillar units <sup>4</sup>	PL	kg	#
Pillar unit SL=500	1305	40	742716
Pillar unit SL=750	1555	46	742717
Pillar unit SL=1000	1805	53	742718
Pillar unit SL=1250	2055	60	742719
Pillar unit SL=1500	2305	66	742720
Pillar unit SL=500-1500	SL+805	<66	742721

5. Engine units	kg	#
Engine unit 150 kg	43	742741
Engine unit 250 kg	43	742742

B. Option	#
Encoder	742256

- The encoder simplifies positioning in the Z direction.
- Mounted in the rotary limit switch.
- Teach-in function.
- Is connected directly to Mechlift Pro (no external PLC).

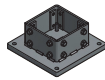

6. Tool adapters	L <sub>t</sub>	kg	#
Tool adapter MP120	15	6,0	731501

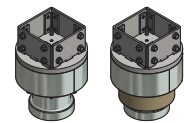

6. Tool adapters	L <sub>t</sub>	kg	°	#
Rotation unit MP120	191	12	0-320	739852
Rotation unit MP120 brake	191	15	0-320	739853

7. Control cables*	#
Control cable L=0,6 m	740937
Control cable L=1,0 m	741586
Control cable L=2,0 m	741678
Control cable L=5,0 m	741679
Control cable L=7,5 m	741680

\* Length L from inner profile to control unit.

8. Control units	#
With emergency stop	742192
With emergency stop + protection	742194
With separate em. stop	742240
With separate em. stop + protection	742241

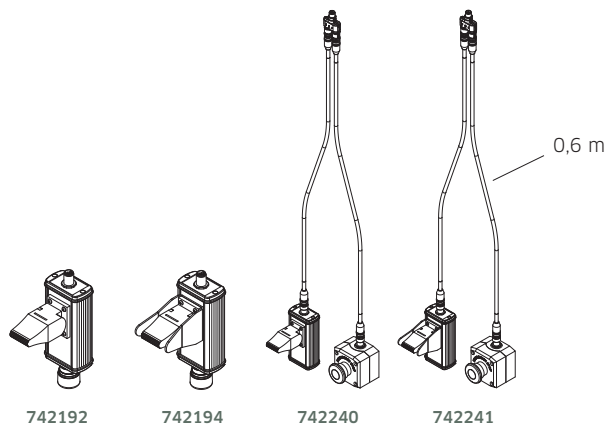

C. Option	Unit	#
Mounting clamp	pc	742242
Wall bracket	set	742243
Adjustable wall bracket	set	742244

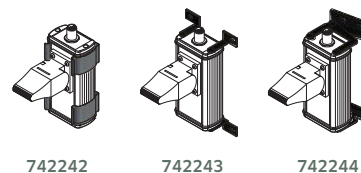

# 150-3 250-3

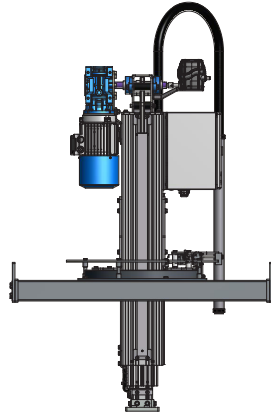

(5) **150-3/250-3 kg** (Min<sup>1</sup>) Max load  
**160/120/80** Profile MP  
**500 Nm** Max moment  
**0,75 kW** Motor output  
**0-10 m/min** Lifting speed  
**500-2000 mm** Stroke SL  
**SL/2+850 mm** Pillar length PL<sup>2</sup>  
**117-203 kg** Tare weight<sup>3</sup>

1. Suspensions	Height PH (mm)	Quantity	kg	c/c	#	#
Suspension PH 50	50	4	0,6	-	733835	733837
Suspension PH 90-210*	90-130-170-210	4	1,1	-	740940	740941
Suspension 4x PH 250-370*	250-290-330-370	1	<10	800	740942	740944
Suspension 4x PH 250-370*	250-290-330-370	1	<11	1000	740943	740945
Suspension 4x PH 410-490*	410-450-490	1	<12	800	740946	740948
Suspension 4x PH 410-490*	410-450-490	1	<13	1000	740947	740949
				Ø (mm)	16,5	20,5
				Fits trolley	AHB1.1/2	AHB3

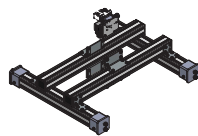

742747 / 742748

2. Cross units	kg	#
Profile cross unit c/c 800	27	742747
Profile cross unit c/c 1000	30	742748

\* Cut to selected suspension height PH, see also Suspensions page 14.

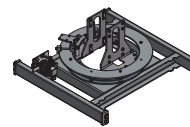

742705 / 742707

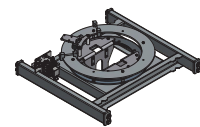

742704 / 742706

2. Cross units	kg	°	#
Steel cross unit, up c/c 800	61	0-310*	742705
Steel cross unit, up c/c 1000	66	0-310*	742707
Steel cross unit, down c/c 800	61	0-310*	742704
Steel cross unit, down c/c 1000	66	0-310*	742706

\* 310-360°, depends on media connection.



A. Option	kg	#
Rotation brake	0,4	742708

3. Media connections	L <sub>m</sub>	kg	#
0-310° (standard)	240	1,4	742736
360° free rotation, 6+12 pol	175	7,3	742737
360° free rotation, 6 pol	175	6,5	742738
360° free rot., 6+12 pol, 2 pneu <sup>5</sup>	175	7,6	742965
360° free rot., 6 pol, 2 pneu <sup>5</sup>	175	6,7	742964

<sup>1</sup> To overcome the frictional force of the sliding blocks

<sup>2</sup> Total length: L = PL + L<sub>m</sub> + L<sub>t</sub>

<sup>3</sup> Depends on configuration

<sup>4</sup> Possible build height BH, see page 15.

<sup>5</sup> Ø4 + Ø8.

4. Pillar units <sup>4</sup>	PL	kg	#
Pillar unit SL=500	1100	38	742722
Pillar unit SL=750	1225	42	742723
Pillar unit SL=1000	1350	46	742724
Pillar unit SL=1250	1475	50	742725
Pillar unit SL=1500	1600	54	742726
Pillar unit SL=500-2000	SL/2+850	<62	742727

5. Engine units	kg	#
Engine unit 150 kg	43	742741
Engine unit 250 kg	43	742742

B. Option	#
Encoder	742256

- The encoder simplifies positioning in the Z direction.
- Mounted in the rotary limit switch.
- Teach-in function.
- Is connected directly to Mechlift Pro (no external PLC).



6. Tool adapters	L <sub>t</sub>	kg	#
Tool adapter MP80	15	2,5	731500

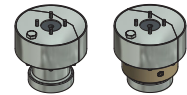

6. Tool adapters	L <sub>t</sub>	kg	°	#
Rotation unit MP80	176	6,9	0-320	739850
Rotation unit MP80 brake	176	10	0-320	739851

7. Control cables*	#
Control cable L=0,6 m	740937
Control cable L=1,0 m	741586
Control cable L=2,0 m	741678
Control cable L=5,0 m	741679
Control cable L=7,5 m	741680

\* Length L from inner profile to control unit.

8. Control units	#
With emergency stop	742192
With emergency stop + protection	742194
With separate em. stop	742240
With separate em. stop + protection	742241

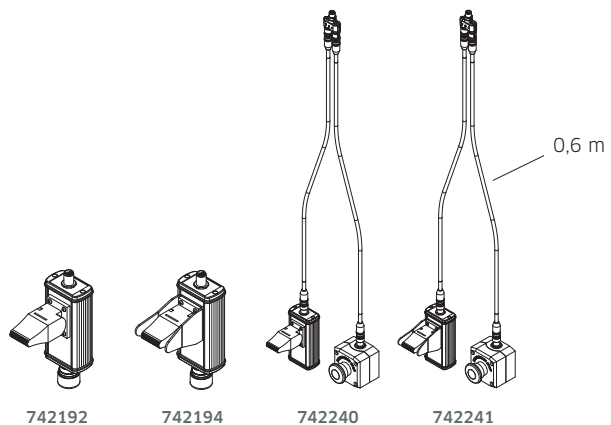

C. Option	Unit	#
Mounting clamp	pc	742242
Wall bracket	set	742243
Adjustable wall bracket	set	742244

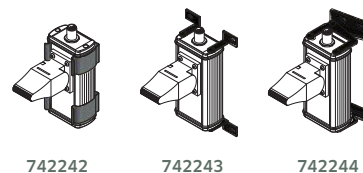

# 400 650

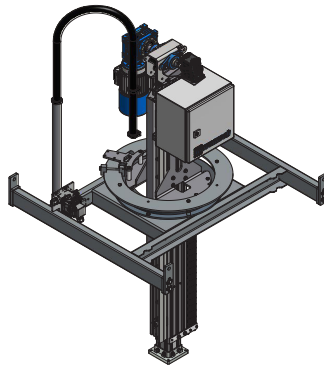

**400/650 kg** Max load  
**160/120** Profile MP  
**1500 Nm** Max moment  
**1,55 kW** Motor output  
**0-10 m/min** Lifting speed  
**600-1500 mm** Stroke SL  
**SL+1000 mm** Pillar length PL<sup>1</sup>  
**164-253 kg** Tare weight<sup>2</sup>

1. Suspensions	Height PH (mm)	Quantity	kg	c/c	#	#
Suspension PH 50	50	4	0,6	-	733835	733837
Suspension PH 90-210*	90-130-170-210	4	1,1	-	740940	740941
Suspension 4x PH 250-370*	250-290-330-370	1	<10	800	740942	740944
Suspension 4x PH 250-370*	250-290-330-370	1	<11	1000	740943	740945
Suspension 4x PH 410-490*	410-450-490	1	<12	800	740946	740948
Suspension 4x PH 410-490*	410-450-490	1	<13	1000	740947	740949
				Ø (mm)	16,5	20,5
				Fits trolley	AHB1.1/2	AHB3

\* Cut to selected suspension height PH, see also Suspensions page 14.

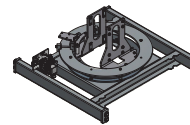

742705 / 742707

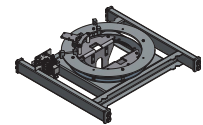

742704 / 742706

2. Cross units	kg	°	#
Steel cross unit, up c/c 800	61	0-310*	742705
Steel cross unit, up c/c 1000	66	0-310*	742707
Steel cross unit, down c/c 800	61	0-310*	742704
Steel cross unit, down c/c 1000	66	0-310*	742706

\* 310-360°, depends on media connection.



A. Option	kg	#
Rotation brake	0,4	742708

3. Media connections	L <sub>m</sub>	kg	#
0-310° (standard)	240	1,4	742736
360° free rotation, 6+12 pol	175	7,3	742737
360° free rotation, 6 pol	175	6,5	742738
360° free rot., 6+12 pol, 2 pneu <sup>4</sup>	175	7,6	742965
360° free rot., 6 pol, 2 pneu <sup>4</sup>	175	6,7	742964

<sup>1</sup> Total length: L = PL + L<sub>m</sub> + L<sub>t</sub>

<sup>2</sup> Depends on configuration

<sup>3</sup> Possible build height BH, see page 15.

<sup>4</sup> Ø4 + Ø8.

4. Pillar units <sup>3</sup>	PL	kg	#
Pillar unit SL=600	1600	68	742728
Pillar unit SL=750	1750	72	742729
Pillar unit SL=1000	2000	79	742730
Pillar unit SL=1250	2250	86	742731
Pillar unit SL=1500	2500	93	742732
Pillar unit SL=500-1500	SL+1000	<93	742733

5. Engine units	kg	#
Engine unit 400 kg	57	742743
Engine unit 650 kg	57	742744

B. Option	#
Encoder	742256

- The encoder simplifies positioning in the Z direction.
- Mounted in the rotary limit switch.
- Teach-in function.
- Is connected directly to Mechlift Pro (no external PLC).

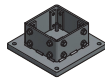

6. Tool adapters	L <sub>t</sub>	kg	#
Tool adapter MP120	15	6,0	731501

7. Control cables*	#
Control cable L=0,6 m	740937
Control cable L=1,0 m	741586
Control cable L=2,0 m	741678
Control cable L=5,0 m	741679
Control cable L=7,5 m	741680

\* Length L from inner profile to control unit.

8. Control units	#
With emergency stop	742192
With emergency stop + protection	742194
With separate em. stop	742240
With separate em. stop + protection	742241

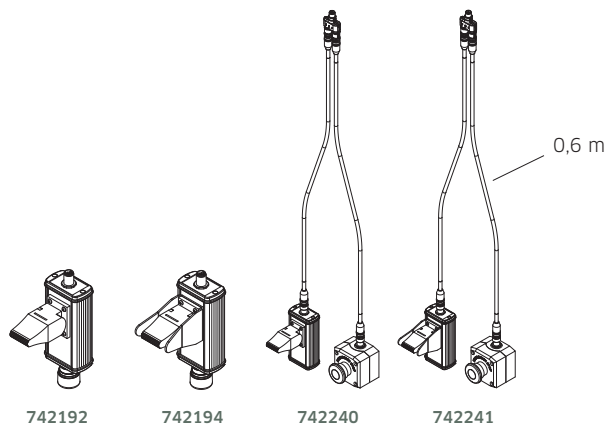

C. Option	Unit	#
Mounting clamp	pc	742242
Wall bracket	set	742243
Adjustable wall bracket	set	742244

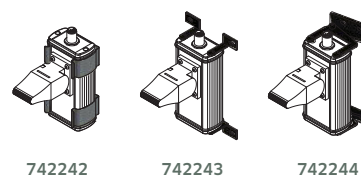

# Suspensions

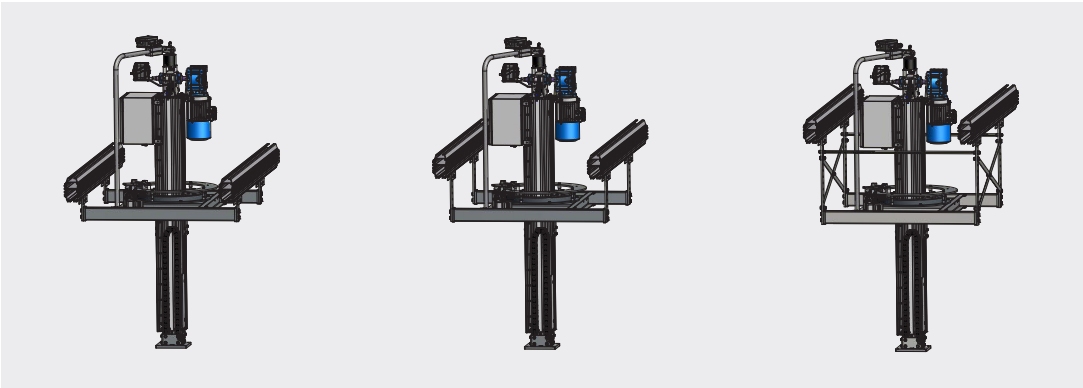
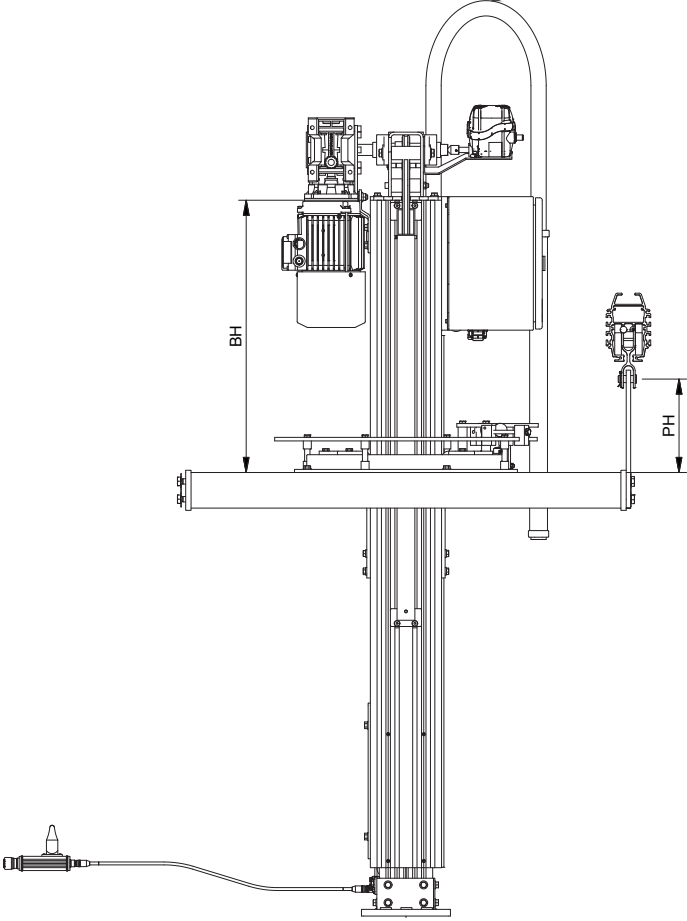

733833/35/37



740940-41 / 742402

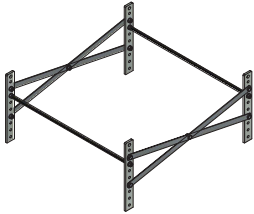

740942-49 / 742403-06

# Build height BH

→ Note that the build height BH is indicated from the upper profile end to the top edge of the cross unit, regardless of version.

## 75 kg

Build height BH	SL	500	750	1000	1250	1500
Profile unit	mm	460 - 850 (655*)	460 - 1100 (780*)	460 - 1350 (905*)	460 - 1600 (1030*)	460 - 1850 (1155*)
Steel unit, up	mm	630 - 960 (795*)	630 - 1210 (920*)	630 - 1460 (1045*)	630 - 1710 (1170*)	630 - 1960 (1295*)
Steel unit, down	mm	450 - 686 (568*)	450 - 936 (693*)	450 - 1186 (818*)	450 - 1436 (943*)	450 - 1686 (1068*)

## 150/250 kg

Build height BH	SL	500	750	1000	1250	1500
Profile unit	mm	460 - 930 (695*)	460 - 1180 (820*)	460 - 1430 (945*)	460 - 1680 (1070*)	460 - 1930 (1195*)
Steel unit, up	mm	630 - 1045 (835*)	630 - 1295 (960*)	630 - 1545 (1085*)	630 - 1795 (1210*)	630 - 2045 (1335*)
Steel unit, down	mm	500 - 770 (610*)	500 - 1020 (735*)	500 - 1270 (860*)	500 - 1520 (985*)	500 - 1770 (1110*)

## 150-3/250-3 kg

Build height BH	SL	500	750	1000	1250	1500	2000
Profile unit	mm	460 - 590 (525*)	460 - 715 (585*)	460 - 840 (650*)	460 - 965 (710*)	460 - 1090 (775*)	460 - 1340 (900*)
Steel unit, up	mm	630 - 710 (670*)	630 - 835 (730*)	630 - 960 (795*)	630 - 1085 (855*)	630 - 1210 (920*)	630 - 1460 (1045*)
Steel unit, down	mm	500*	500 - 575 (510*)	500 - 700 (575*)	500 - 825 (635*)	500 - 950 (700*)	500 - 1200 (825*)

## 400/650 kg

Build height BH	SL	600	750	1000	1250	1500
Profile unit	mm	460 - 580 (520*)	460 - 830 (645*)	460 - 1080 (770*)	460 - 1330 (895*)	460 - 1580 (1020*)
Steel unit, up	mm	630 - 650 (640*)	630 - 775 (700*)	630 - 900 (765*)	630 - 1025 (825*)	630 - 1150 (890*)
Steel unit, down	mm	500 - 520 (510*)	500 - 670 (560*)	500 - 900 (675*)	500 - 1025 (735*)	500 - 1150 (800*)

\* Default value

# Mechlift Pro E

For more information,  
contact your sales representative.

MOVOMECH AB  
Kabelvägen 9  
S-291 09 Kristianstad, Sweden  
Telephone: +46 (0)44 - 28 29 00  
E-mail: [info@movomech.se](mailto:info@movomech.se)  
[www.movomech.com](http://www.movomech.com)

